



SSD Granulator

Operating Instructions



MACHINE-TYPE: intimus SSD Granulator
MACHINE-NUMBER: 2752
YEAR: 2021



intimus International GmbH
Bergheimer Straße 6 - 16
88677 Markdorf
Germany

Tel.: ++49 (0)7544 / 60-0
Fax.: ++49 (0)7544 / 60-248
e-mail: sales.de@intimus.com

Before operating carefully read the Operating Instructions!

CONTENTS

1 CONTENTS

1	CONTENTS.....	2
2	Description of Symbols	4
3	General.....	5
3.1	Warranty and Liability	5
3.2	Copyright.....	5
3.3	Convention, intended use	6
3.4	Organisational measure	7
3.5	Personnel selection and qualification; basic responsibilities	8
4	Security information.....	9
4.1	Normal mode.....	9
4.2	Special works in the course of operation and maintenance as soon as troubleshooting during operation; waste disposal.....	10
4.3	Reference to possible cause of risks.....	11
5	Function of the machine	12
6	Technical Data	12
7	Workable materials	13
8	Vapors and Dust.....	14
9	Suggested Feed Rates	15
10	Machine set-up	16

CONTENTS

11	Operation Manual	17
11.1	Mounting information:	17
11.2	Operating information:	17
11.3	Operating	17
11.4	Troubleshooting.....	20
12	Cleaning of shredding unit and screen	21
12.1	Cleaning of shredding unit.....	21
12.2	Cleaning of the screen.....	21
12.3	Exchange & cleaning of screen on shredder	22
13	Lubrication and services	25
13.1	Cylindrical gears	27
14	Declaration of EC-Conformity	28
15	Reference to product liability	29
16	Reference to improper use of the machine:.....	29
17	Manufacturer and Service Provider:	29

Appendix:

- Specifications of control system
- Circuit diagrams
- List of electrical components
- Dimensional drawing
- Spare parts list
- Description of purchased parts

2 Description of Symbols



Information!
Important application note



Attention!
Danger of destruction or damaging of machine or facility

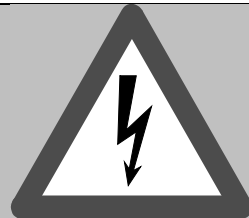

Danger!
Danger for life or physical condition

3 General

3.1 Warranty and Liability

General terms of intimus International GmbH apply.

Warranty and Liability claims are excluded, if any of the following applies:

- Inappropriate use of the machine
- Improper installation, commissioning, set-up, operation or servicing of the machine
- The machine was designed for safe operation by trained and instructed staff only and is not designed to be used by children.
- No other works may be performed on the machine during cleaning or servicing
- If the machine was used:
 - with inoperative safety devices
 - with incorrectly installed safety devices
- Non observance of the references related to:
 - transport
 - installation
 - start-up
 - set-up
 - maintenance
 - Unauthorised physical/structural modification of the machine
 - Unauthorised intervention into the control system
 - Emplacement and use of unapproved components and spare parts
 - Faulty repairs by non-trained and un-authorized personnel

3.2 Copyright

The operation manual in hand and associated documents remain property of intimus International GmbH. They are handed to our customers and users of our products.

Without our explicit permission it is prohibited to copy these documents or hand them over to third parties, especially to our competitors.

3.3 Convention, intended use

3.3.1

- The machine is built according to state of the art technology and to generally approved safety regulations
- Nevertheless, when using unless used strictly in accordance with the instructions and by a trained operator then the operator and third parties may place themselves in harm's way.
- adverse effects to the machine and other material property

3.3.2

- Use the machine only in proper technical condition
- Use the machine only under awareness of safety & danger and in full compliance with the operation manual
- Permanently check and repair any malfunctions of the machine especially regarding damage of safety switches and interlocks, which in case of damage and malfunction must be repaired without any delay by qualified personnel
- The machine is to be used:
 - only for the purposes for which it was originally designed and built
 - only for the purposes as described in the operator manual, see chapter 7 of this manual
 - for industrial and commercial use only
- Any other usage than specified above is out of designated use
- The manufacturer or supplier is not liable for any damages if the machine is not used and maintained in the correct manner
- The operator bears the full risk of any such damages
- The operator must be suitably trained on the equipment, have full knowledge of the operation manual and be aware of all safety, usage and maintenance requirements.

3.4 Organisational measure

- The operation manual must be readily available at the machine.
- In addition to the operation manual users are obliged to observe:
 - general legal requirement and regulations
 - full accident prevention regulations
 - environment protection regulations
 - personnel protective equipment is to be provided by the operating company
- Local and internal instructions are to be respected and adhered to
- Before starting any work on the machine the operating personnel has:
 - to respect the basic rules for job safety and accident prevention
 - to read, understand and acknowledge all aspects of job safety pertinent to the operation of the machine.
- The behaviour of the operating personnel in accordance with the safety regulations must be checked and corrected by the operating company
- It is forbidden for any personnel working on or near the equipment to have long, untied hair, loose clothing or jewellery, or any other items that may potentially get caught by the equipment in case of:
 - risk of injury
 - getting caught whilst near or feeding into the machinery
- Personnel must be equipped with and wear suitable protective clothing
- All safety and hazard notifications on the machine or in the instructions must be respected
- All safety and hazard signs on the machine must be in readable state
- In the case of any security or safety related issues, or if any changes are noted in performance relating to the machine, the unit must be stopped immediately and reported and recorded both to a suitable responsible person internally, and in consequence to the supplier

General

- Without consent and approval of the supplier:
 - No modifications must be made to the machine
 - No changes or adjustments are to be made to the height of the machine in relation to the floor or which would change the operating height in relation to the operator
 - The operator must not stand on higher ground than the machine when feeding the machine and must never stand on any raised platform such as a pallet or box placed in front of the machine which might reduce the distance between operator and cutting system to a level which does not meet the required safety standards
 - No modifications of calibrations of any of the safety devices must be made which may impair safety.
- Use only original spare parts or those that are conforming to the specified technical standards
- Do not make any modifications in programmable control systems
- Always keep terms of any issues relating to performance, modification and safety mentioned with the manual
- For performing any maintenance task, proper workshop equipment is absolutely essential
- Provide, communicate and record the location and handling of suitable fire extinguishers
- Observe and record any fire call and fire fighting

3.5 Personnel selection and qualification; basic responsibilities

- The operation of the equipment is only allowed to be executed by reliable personnel. Always observe the lawful minimum age
- Clearly define the responsibilities of personnel for operating, servicing and maintenance
- Ensure, that only fully instructed personnel works on or uses the equipment
- Carefully write down and communicate who will be the responsible person for the training of machine operators
- Personnel to be trained is only allowed to work at the machine under permanent observation by a suitably trained supervisor, who is in the position to reject any safety-adverse directives from third parties
- Electrical requirements are to be carried out by authorised and suitably qualified electricians/trained personnel. Observe applicable rules and regulations relating to local requirements

4 Security information

Read carefully before start-up of the machinery!!!

4.1 Normal mode

- Minimum age of persons to operate the machinery is 16 years
- Inside the working area of the machine, the operator is responsible for other persons
- The machine must be placed on even and solid ground.
- Before leaving the machine: turn-off main switch and protect it against unauthorised start-up.
- Maintenance and cleaning as well as the removal of the safety devices are only allowed with main switch turned-off (ensure that the main switch cannot be turned-on).
- Ensure that safety devices supplied with the machine are in function and use.
- Do not access the cutting knives. Danger of serious injury!
- Collecting containers for shred goods must be suitable for the shredded materials and their residual liquids.
- Dangerous goods and improper materials must be separated from the waste before shredding and be disposed separately (e.g. cans and containers used for highly inflammable and explosive substances).
- Waste that can produce loops/tails must be pre-treated separately to disable it to create danger of injury by pulling the operator or other materials into the shredding unit. I.e. do not feed a material with tails that could become tangled drawing the operator or persons in the vicinity towards the machinery.
- The operator has to be trained on the machine and must always wear appropriate safety clothing.
- Take measures for continuous operation of the machine in a safe and functional condition. Use machine only, when protection devices and safety attachments are installed and also functional

Security information

- Check the machine for external visible damage and defects on a daily basis or before any new operation starts
- Be aware of any changes to the equipment, including the operating performance. Inform the responsible person about any changes. If any change occurs immediately stop the machine and shut down and carry out checks. Do not re-start until being confident there is no fault or problem.
- In case of malfunction of the machine: stop and protect it against unauthorised start-up. Clear fault without any delay
- Before starting the machine assure that nobody will be at a risk

4.2 Special work in the course of operation and maintenance as well as troubleshooting during operation; waste disposal

- Observe the terms for service and maintenance. These tasks must be executed by qualified personnel only
- The operating personnel and supervisors are to be informed before service tasks will take place
- If necessary, block off and mark a suitable service area
- Before service/maintenance: clean the machine from oil
- Do not use aggressive cleaning agent
- Use fibre-free cleaning rags
- After demounting of safety devices for servicing or maintenance works always re-install and test them before operating the machine
- Take care for environmental friendly disposal of operating materials fluids and replacement parts

4.3 Reference to possible cause of risks

4.3.1 Power supply

- Operations in the power supply system must be executed by qualified personnel only
- The switch cabinet must always be closed
- Access to any electrical part by authorised personnel with key only

4.3.2 Noise

- Permanent sound level of the machine in idle mode: max. 70 dB(A)
- Depending on the working processes the sound level can be higher
- Personal ear protection is mandatory

4.3.3 Oil, grease and other chemical substances

- Handling of oil, grease and other chemical substances only in accordance with safety regulations for the corresponding material

5 Function of the machine

Exchangeable hardened cutting discs are mounted on two counter rotating steel shafts

Materials such as optical, magnetic and FLASH data media are drawn into cutting shafts and cut into pieces.

Depending on requested security level the shredded chips can be shredded once more to reach the target size or, if necessary, a screen can be optionally installed underneath the cutting unit with hole diameters of e.g. 5 or 3 mm to reach the target security level.

The drive and cutting unit is protected against overload by an electronic torque limiter with reversing movement.

6 Technical Data

Flash media shredder		intimus SSD Granulator
Cutting area		159 x 347 mm
Drive		2,2 kW 400V / 50Hz
Current consumption	P	5,1 A (in case of overcharge: temporary
	I _N	rising of charging rate to 3x I _N possible)
Fuse		16 A
Revolutions		17 1/min
Machine number		2752
Year		2021
Noise level max.		≤ 70 dB(A) - in no load operation
Weight		approx. 520 kg

7 Workable materials

Intimus SSD Granulator is designed to shred FLASH media. CDs, DVDs floppy discs and smart cards can be processed as well when feeding them carefully and mixed with FLASH media (these materials are less brittle and thus need more cutting power, also, they create more friction in the cutting system and tend to get soft and melt with increasing temperature). **It is recommended to remove metal clips or removable covers from thumb drives before shredding.** These parts do not contain data and increase the wear and reduce the throughput. The machine is NOT suitable to shred magnetic HDD's. Intimus SSD Granulator is designed to be fed via a special funnel for max. media size of approx. 138 x 200 x 40 mm (l x w x h). **For processing of any alternate products please contact the supplier for written approval and advice.**

Whilst cutting head parts are specially hardened it must be noted that media contain tough materials including metal parts which wear the cutting head of the shredder after varying time, depending on type, size, quality and volume of shredded goods. Data media may contain parts which by their nature might remain within the cutting unit including cutters, spacers etc. It is highly recommended therefore that these particles are removed from the machine on a weekly basis or earlier if the capacity throughput of the unit decreases.

It must also be noted that you should never try to shred any type of hardened metal like the head of a hammer as this will permanently damage the cutting knives and associated parts.

Please note that the unit should be placed under a suitable annual preventative maintenance contract from new by a trained engineer or the guarantee may get void.



Attention!

Do not use material which contains poisonous or caustic substances or substances which develop corrosion or which are combustible.

8 Vapors and Dust

ATTENTION! During shredding vapor and dust may emerge.

1. Depending on the individual shredding material and the assembled screen, flammable **dust** may develop during the shredding process. The smaller the mesh size of the assembled screen, the smaller particles are created and the higher the dust contents is in the shredding material. Due to the vast multitude of data media and their manufacturers, we cannot give general advice if an when flammable dust is generated. Thus **it is in the responsibility of the operator** to monitor developing of flammable dust for his specific shredding situation depending on the individual shredding material and assembled screen **and take appropriate action** in accordance with applicable standards and rules.
2. Depending on the individual shredding material and the assembled screen, harmful **vapors and dust** may develop during the shredding process. The smaller the mesh size of the assembled screen, the smaller particles are created and the more likely it is that small components on PCB-boards are cut, which may release liquid or aeriform substances. Due to the vast multitude of data media and their manufacturers, we cannot give general advice if an when harmful vapor or dust is generated. Thus **it is in the responsibility of the operator** to monitor developing of harmful vapor or dust for his specific shredding situation depending on the individual shredding material and assembled screen **and take appropriate action** in accordance with applicable standards and rules. At any rate it is recommended, to follow the basic guidelines for electronic scrap recycling to **not employ pregnant women in the room** where the shredder is situated, and to **interdict eating, drinking and smoking in this room** for all employees. As an option, the shredder can be equipped with a connecting port for an existing dust extraction plant for collection and disposal of dusty and aeriform emissions of the machine.

9 Suggested Feed Rates

To avoid jamming when operating the machine with sieve and the following long-winded clearing of the jam and eventual damages to the machine, the feed rate must be equal to the output of the sieve. With a smaller meshed sieve the output will decrease as well.

**Attention!**

The operator must define the output of the machine with his specific shredding material and the installed sieve and adapt his feed-rate accordingly.

For standard thumb drives of the most common “Twister” type (see photo) intimus has evaluated for ease of operation the following suggestions for feed rates:

Thumb drive w/o metal clip at 5 grams weight

- 1 drive every 6 seconds with 3 mm screen
- 1 drive every 3 seconds with 5 mm screen
- 2 drives per second without screen

Thumb drive with metal clip at 15 grams weight

- 1 drive every 20 seconds with 3 mm screen
- 1 drive every 10 seconds with 5 mm screen
- 1 drives per 1,5 seconds without screen



It is important to feed data media continuously with the prescribed feed rates. When feeding more media in longer intervals, the limited space between knives and screen will overfill and the machine may start jamming. When the jam cannot be cleared by pressing the start, after a few seconds the stop and then the reverse buttons and continuing so until the machine runs freely again, the screen must be removed for clearing the jam, which costs more time than following the suggested feed rates

Depending on size, material and weight of your individual media shorter or longer intervals may be chosen according to the actual load level. Please note that the above mentioned figures are based on intimus internal tests. Data media, which intimus used for their tests, may achieve different throughput figures than your specific material.

For this reason each operator must determine the output of the machine with his specific shredding material and adapt his feed rate accordingly.

Damages which result out of overloading are excluded from warranty.

10 Machine set-up

1. It is recommended that the unit is installed and set up by a qualified technician trained by the manufacturer
2. Please carefully read the operation manual and the Security and Safety Information.
3. Remove the external packing material
4. Remove the pallet by lifting the machine from the bottom with hand lift truck or stacker. **ATTENTION** - Please note that depending on the configuration of the unit there may be a high centre of gravity and if so, it may be necessary to lift it by crane at the 4 eyebolts at the machine. Please contact the manufacturer for details.
5. After the machine has reached the operating position, apply the brakes on the guide casters.
6. Connection of the machine to the power supply system must only be done in accordance with local regulations like VDE, UL, CSA etc.

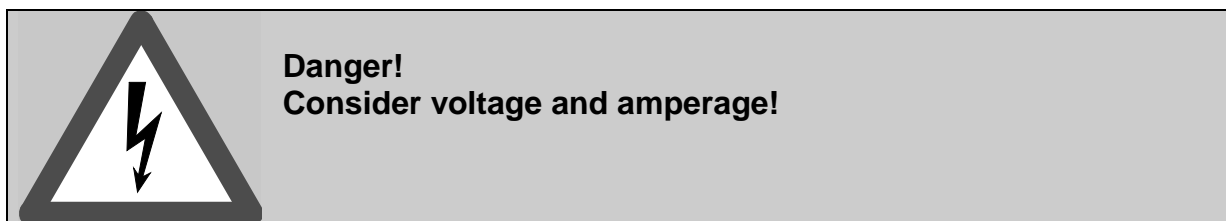

7. Check rotation direction of cutting shafts: driving motors must turn in direction of arrow on their cooling fan cover. If the rotation direction is not correct, change of direction must be done by a trained electrician.
8. Fully instruct the operating personnel prior to starting-up of the equipment
 - Make them familiar with the basic regulations of job safety and accident prevention

11 Operation Manual

11.1 Mounting information:

The machine must not be operated outdoors. It must be installed stable on even and solid subsoil base.

Attention: Please apply the brakes before operating.

11.2 Operating information:

Fill only shreddable parts in the shredding unit, no solid, massive parts. (see Chap.7).



Attention!

No warranty applies when shredding other parts not approved by the manufacturers.

11.3 Operating

Turn main power switch on

To note: main switch can be locked for maintenance operation by a padlock in off position



If activated, unlock emergency-stop switch by pulling

If several emergency-stop buttons are installed, please unlock all of them.

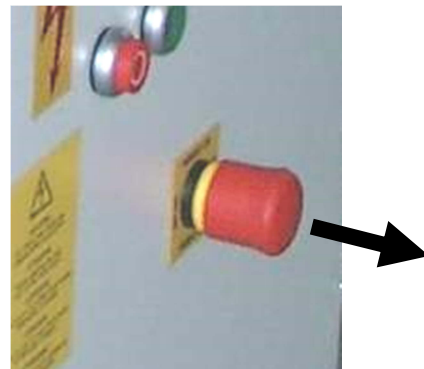

To start the machine – press the green push-button



To stop the machine – press the red push-button



Reverse mode:

1. push emergency-stop button and pull it out again



2. Then press the black reverse push-button



Please note that the hopper cover and doors at the machine have to be closed during operation. After opening and closing please restart the machine.

Attention!

In case of disturbances or if hazards to the operator will occur during normal operation, **emergency-stop button(s)** will have to be pushed immediately.

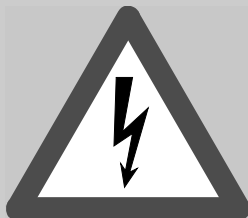
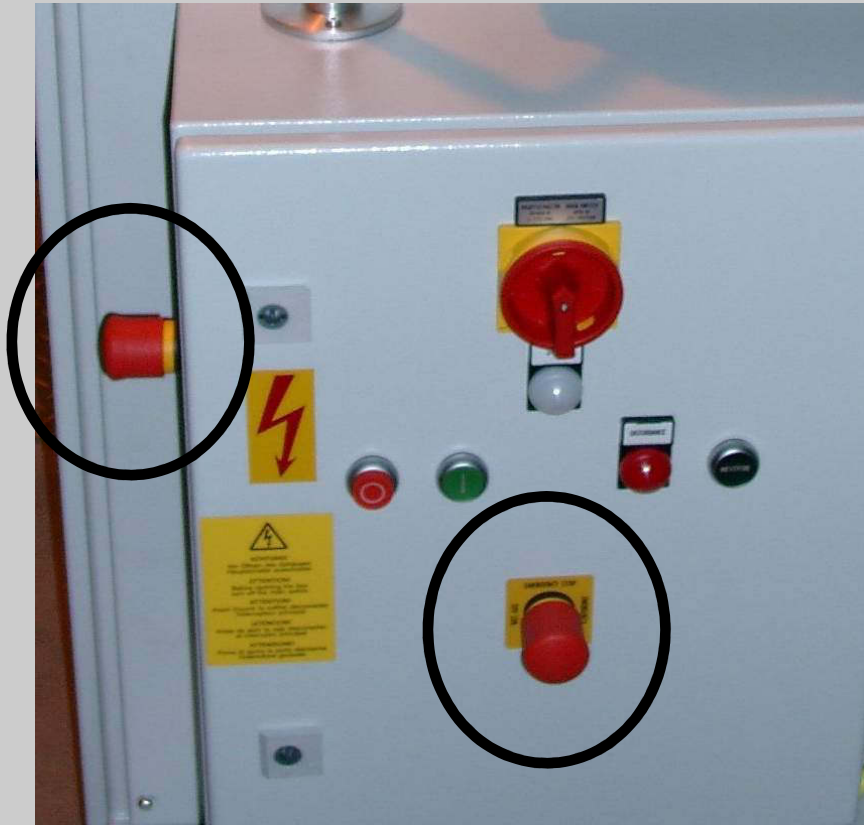

Suggested Feed Rates

See chapter 8

11.4 Troubleshooting

IF RED DISTURBANCE LIGHT ON CONTROL PANEL IS ON

- is the emergency stop button pressed in → pull out
- is the front collection door open → closed it
- is the hopper open and unlocked → close and relock
- is shredded waste container full → empty the container
- Is one of the safety switches on door or hopper damaged → immediately call a technician in charge

If this fault message appears several times in a row, switch-off main switch and lock main switch against switching-on.

Possible causes of fault:

- There is non-cuttable material in the machine → Remove it
- Cutting space is blocked by too much material → empty the cutting space

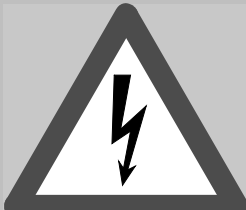
	<p>Danger! Before servicing takes place in the danger area of the shredding machine: push emergency-stop and lock the main switch surely against engaging!</p>
-------------------------------------------------------------------------------------	---------------------------------------------------------------------------------------------------------------------------------------------------------------------------

	<p>Information! A half-yearly service checks through trained persons recommended.</p>
-------------------------------------------------------------------------------------	--------------------------------------------------------------------------------------------------

12 Cleaning of shredding unit and screen

12.1 Cleaning of shredding unit

The shredding unit should be cleaned once a week.

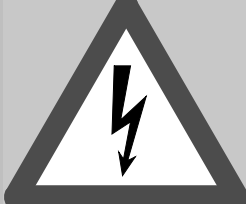
	<p>Danger! Before cleaning ensure that the main switch of the shredding machine cannot be switched on.</p>
-----------------------------------------------------------------------------------	-----------------------------------------------------------------------------------------------------------------------

12.2 Cleaning of the screen

Certain materials may collect within the cutting unit. It is highly recommended to remove these parts from the machine on a weekly basis or earlier if the capacity throughput of the unit will be reduced. These parts will eventually block the screen and if not removed on a regular basis they may cause serious damage.

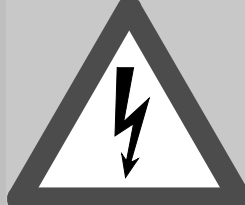
	<p>Danger! Before cleaning ensure that the main switch of the shredding machine cannot be switched on.</p>
-------------------------------------------------------------------------------------	-----------------------------------------------------------------------------------------------------------------------

	<p>Attention! Staff must be provided with suitable clothing including eye protection, gloves and hard shoes etc. as the parts can be very sharp.</p>
-------------------------------------------------------------------------------------	-----------------------------------------------------------------------------------------------------------------------------------------------------------------

12.3 Exchange & cleaning of screen on shredder SCC Granulator

Procedure:

1. Switch-off machine and ensure that the main power switch cannot be switched-on again until the service process is finished.
2. Open front door and remove the waste container. Also remove the rear sheet steel cover of the machine.
3. Prop up screen from underneath with the help of the optional intimus lifting device or a forklift or hoist to support the screen before loosening the screen's fixing bolts.



4. Loosen the bolts "A" (3 x allen bolts M10 each on front and rear side of the cutting unit (see picture 1).
5. With the help of the lifting device move the screen downwards out of the cutting unit when all bolts are removed (see picture 2). Please note that the weight of the screen is approx. 11 kg.

pict. 1

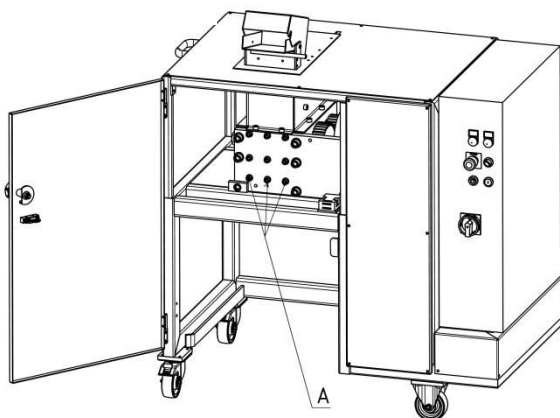

pict. 2

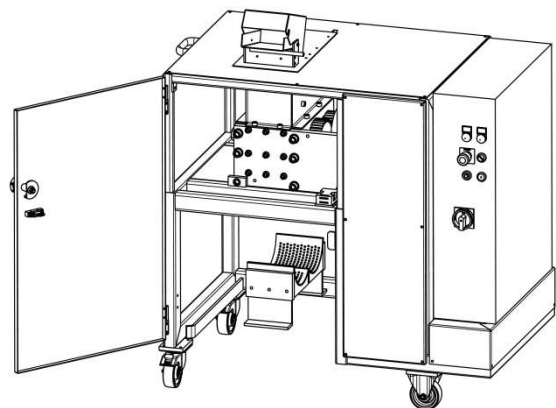

6. If the screen is stuck and will not slide down by gravity, you may use a crowbar (naildrawer / assembly lever) to pull it out of the chassis. Attach it between the foot of the screen and the chassis of the machine and pull the screen down



7. Once lowered draw out the screen from under the shredder and remove all data media particles from accessible areas underneath the cutting knives and from the screen surface with suitable tools like heavy duty pliers. Also unblock the screen holes with a suitably sized punch. Be careful to not damage the screen

The re-assembly of the screen after cleaning is to be done in reverse order. There is no specific position of the screen for proper installation like on other intimus machines, you may put it either way into the machine. **Attention: bring the platform with the screen up so that the platform is above the door switch and the guide bars of the collecting bin, but also ensure that the screen is low enough to match under the chassis.** Then carefully position the screen so that it matches with the opening of the cutting block and carefully lift it into the cutting block. Finally it will get in touch with the combs within the cutting block.

At the feet there will remain a gap towards the chassis, so do not try to lift the screen any further, else you will lift the complete machine. Then the holes in the cutting block should match with the threads in the screen so that you can assemble the 3 large allen head bolts at the front and rear side of the cutting block. First tighten the 3 bolts at the front carefully, then the 3 bolts at the rear.



Further instructions and pictures will follow later in this chapter.

Please ensure that the screen is laying horizontally on the lifting table.

Move the lifting table with screen underneath the shredding unit and lift it up against block.



Tighten the screws on both sides of the cutting unit.



Remove the lifting table from the machine.



The M10 allen bolts (6x) must be re-tightened by using a fastening torque with 46 kN

13 Lubrication and services





<u>servicing periods</u>	<u>working steps</u>	<u>recommended lubricants</u>
Every week or 40 working hours		
synchronizing gears cutting unit	greasing	5
bearings cutting unit	greasing	8
cutting unit	cleaning from waste	
screen	disassembly and cleaning	
Every 6 months or 500 working hours		
synchronizing gears cutting unit	checking oil level,	6
		checking for oil leaks
cutting shafts	check for wear	-
screen	check for wear	-
gearbox of main drive	checking oil level, checking for oil leaks	mineral 1 synthetic 6
Every 2 years or 10,000 working hours		
synchronizing gears cutting unit	changing oil	1 , 6
gearbox of main drive	changing oil	mineral 1 synthetic 6
bearings cutting unit	exchange grease	7 , 8



Attention!

Do not use or shred material which contains poisonous or caustic substances or substances which develop corrosion or which are combustible.

Lubricant recommendation

kind of use	kind of lubricant	surrounding temperature °C	kin. viscosity at 40°C (cST) mm²/s						
synchronizing gears, gearbox motors	oil	1 + 40 to 0	242 to 198	ARAL Degol BG 220	BP Energol GR-XP-220	SPARTAN EP 220	MOBILGEAR 630	SHELL Omala Öl 220	Meropa 220
		2 + 25 to - 15	165 to 90	ARAL Degol BG 100	BP Energol GR-XP-100	SPARTAN EP 150	MOBILGEAR 629	SHELL Omala Öl 100	Meropa 150
		3 + 10 to - 30	74,8 to 13,5	ARAL Degol BG 46	BP Energol GR-XP-68	ESSO Automatic Transmission Fluid	MOBIL D.T.E. 15	SHELL Tellus T 32	Meropa 68
		4 - 20 to - 50	16,5 to 13,5	ARAL Vitamol 1010	BP Bartran HV 15	UNIVIS J 13	MOBIL D.T.E. 11	SHELL Tellus T 15	Aircraft Hydraulic Oil 15
	grease 5 + 40 to - 15		ARAL Aralub FDP 00	BP Energrease HT-EP 00	FIBRAX EP 370	MOBILPLEX 44	SHELL Grease Alvania GL 00	Multifak EP 0	
common use	synth. 6 oil	+ 80 to - 25	352 to 198	ARAL Degol GS 220	BP Energol SG-XP-220		MOBIL Glygoyle 80	SHELL Tivela S220	
	synth. 7 grease	+ 60 to - 20				Getriebe-fließfett S 420	RR.103B Glygoyle Grease 00	SHELL Tivela GL00	
bearings for	common	grease 8 + 60 to - 30		ARAL Aralub HL 3	BP Energrease LS 3	ESSO Mehrzweckfett BEACON 2	MOBILUX EP 2	SHELL Alvania RL3 (alt: R3 oder G3)	Glissando FT 3
	gearing	9 + 80 to - 40				MOBILTEMP SHC 100			
		synth. 10 grease + 60 to + 100					ESSO Unirex N 3		
	motor	11 - 30 to - 45		ARAL Aralub SKL 2		Beacon 325	MOBIL THERM p SHC 32	AERO SHELL Grease 16 AERO SHELL Grease 7	

13.1 Cylindrical gears

Lubricate once a week with universal grease (temperature range from -30°C to $+60^{\circ}\text{C}$)

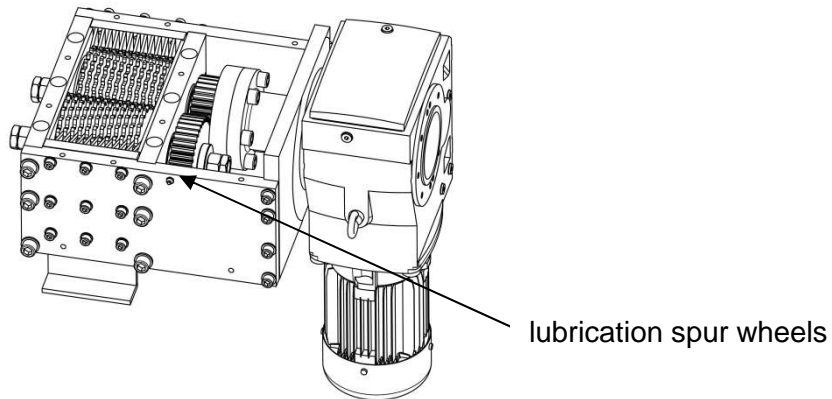

Information!

The type of lubricants could be taken out from the included operating and maintenance instruction of unicast-helical-gearboxes.

Declaration of EC-Conformity

14 Declaration of EC conformity

Konformitätserklärung Certificate of Conformity Attestation de Conformité Certificado de Conformidad



Bezeichnung der Maschine:	Spezialshredder (f. SSD-Laufwerke)
Type of machine:	Special Shredder (f. SSD drives)
Description de la machine:	Destructeur spécial (pour lecteurs SSD)
Descripción de la máquina:	Destructora especial (p. unidades SSD)
Modell / Model / Modèle / Modelo:	SSD Granulator
Typ / Type / Type / Tipo:	555
Artikel-Nr. / item number / numéro d'article / número de la pieza:	5553xx
Serien-Nr. / serial number / numéro de série / número de serie:	5553xx.000xx.xxx
Baujahr / year of manufacture / année de production / año de producción:	siehe Typenschild / see type plate / voir plaque d'identification / mirar la placa de identificación

Hiermit wird bestätigt, dass vorgenanntes Produkt den Anforderungen der **Maschinen-Richtlinie 2006/42/EG** einschließlich allen bis heute veröffentlichten Änderungen bzw. Nachträgen entspricht. Das vorgenannte Produkt entspricht folgenden harmonisierten bzw. nationalen Normen:

We do hereby certify that the above mentioned product meets the requirements set forth in **EEC-Guidelines 2006/42** including all changes and addendums to date thereto. The above mentioned product meets the following harmonized and national standards:

Nous vous confirmons que le produit cité ci-dessus correspond aux **exigences des directives 2006/42/CEE**, ci-inclus toutes les modifications ainsi que tous les suppléments publiés jusqu'à ce jour. Le produit mentionné correspond aux normes citées ci-après:

Confirmamos que los productos arriba citados cumplen las exigencias de las **directivas 2006/42/CEE**, incluidas todas las modificaciones publicadas hasta la fecha. Los productos citados corresponden con las siguientes normas:

**Harmonisierte Normen / harmonized standards
normes harmonisées / normas armonizadas**

**Nationale Normen / national standards
normes national / normas nacional**

**EN ISO 12100
EN ISO 13857
EN ISO 14121-1
EN 60204**

CE-Bevollmächtigter / authorized person of CE / personne autorisée de la CE / persona autorizada por CE:
intimus International GmbH; Bergheimer Straße 6-12; D-88672 Markdorf / Germany



Postfach / p.o. box 1420
88672 Markdorf / Germany

2021/04

Ulrich Niedermeier
CTO
(Chief Technical Officer)

15 Reference to product liability

According to EC regulations 1999/34/EG valid since May 10, 1999, the manufacturer is only liable for his product when all parts are originally supplied by the manufacturer or are released by the manufacturer – and the machine will be operated in accordance to the regulations given by manual in hand.

When using external accessories or spare parts the product liability of the manufacturer will not be to apply in total or partial. In extreme cases the use of the complete machine can be denied by the appropriate authorities.

16 Reference to improper use of the machine:

In case of improper use of the machine the product liability of the manufacturer expires. E.g. if materials will be shred which deviates from the material tested and released by the manufacturer. See hereto also chapter 3.

17 Manufacturer and Service Provider:

intimus International GmbH
Bergheimer Strasse 6 - 16
88677 Markdorf

Telefon 07544 / 600 Telefax 07544 / 60248

E-Mail: sales.de@intimus.com