

Comb Binding Machine

GB





CAPABILITIES

Technical Data

Width	: 300mm
Punching Thickness	: 15sheets
Punch PVC Cover	: 2sheets
Punch PP Cover	: 1sheet
Machine Dimension	: 44.5x21x28.8cm
Weight	: 5kgs
Binding Thickness	: 500sheets
Pitch	: 14.25
Numbers of Punch Pins	: 21

IMPORTANT SAFETY INSTRUCTIONS-KEEP FOR FUTURE USE



Please read before use and keep for future

When punching;

- always ensure the machine is on a stable surface
- test punch scrap sheets and set the machine before punching final documents
- remove staples and other metal articles prior to punching
- never exceed the machines quoted performance

Keep the machine away from heat and water sources.

Never attempt to open or otherwise repair the machine.

SET UP

1. Ensure the machine is on a solid surface



2. Check the waste tray is empty and correctly fitted

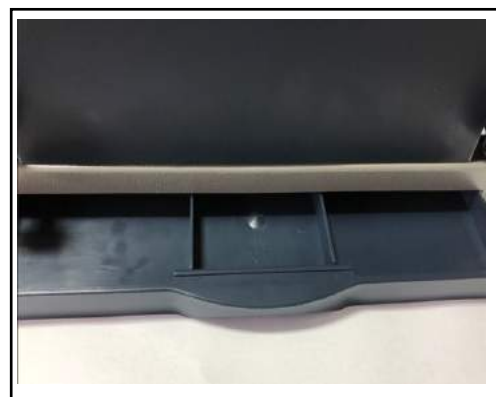

PUNCH

1. Adjusting paper guide to the corresponding paper size.
Release attachment screw, adjust paper guide and fasten attachment screw.



2. Determine the diameter.
Put the block under the measuring scale.
Push slider downwards.
Read the diameter of the binding element .



3. Adjusting the margin turn right knob to the corresponding size



4. Insert paper into punching slot,
Press punching lever forward until it stops,
then return to original position

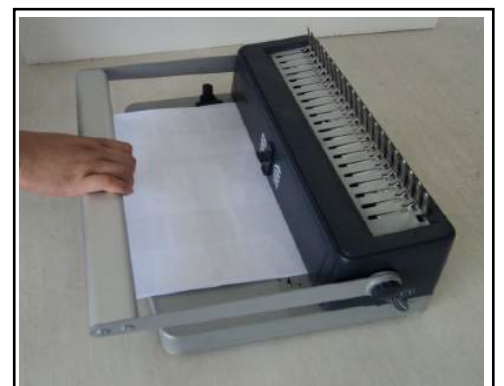

PUNCH

5. Ensure the paper is less than 15 pieces

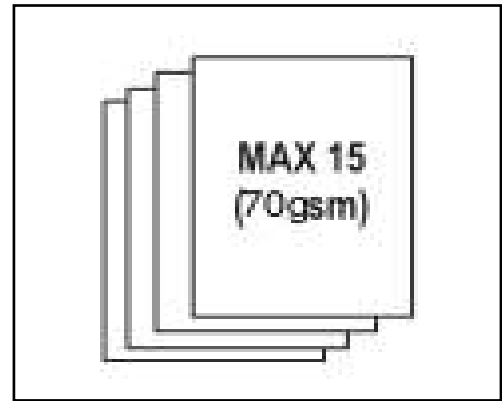

BIND

1. Caution! Lay the plastic binding element with its spine behind the vertical retaining fingers and its rings facing down through the gaps in the fingers.

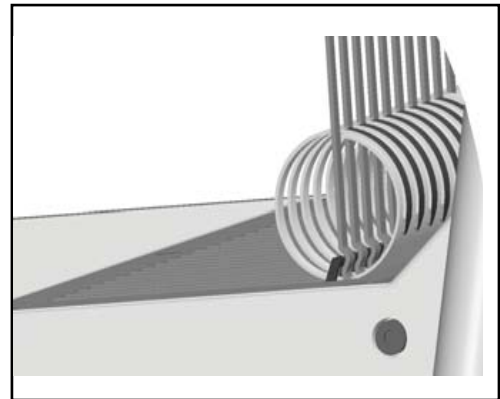

2. Open the binding comb by pushing the binding lever backward.

Caution! Do not open the comb too wide as there is danger of over-stretching it which may weaken the plastic.



3. Take the punched paper with both hands and insert it directly onto the open rings of the binding element



BIND

4. Lay down paper to the front.
Close plastic comb by returning the binding lever to stop.

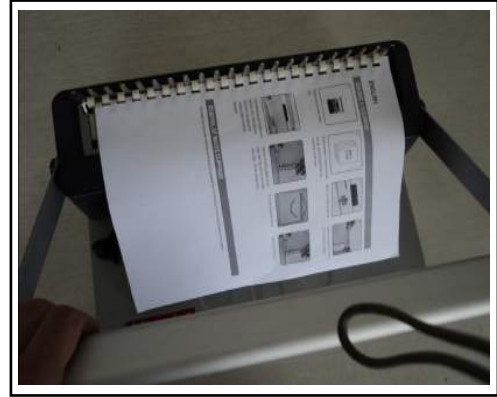

REMOVE BOUND BOOK

1. With the binding lever in the rear position, slide the bound book over the comb by pushing the binding lever backwards.



2. Remove the desired pages, punch and insert the new ones.
Proceed the same way as initially.



REMOVAL OF WASTE CLIPPINGS

The waste tray is located under the machine and is accessed from the front side. For best results empty the tray regularly.

TROUBLESHOOTING

Problem	Cause	Solution
Punched holes are not central	Edge guide not	Adjust edge guide until hole pattern is correct
Machine will not punch	Blockage	Check waste tray is empty. Check for blockage
Punch holes are not parallel to edge	Debris is stuck below dies	Take stiff cardboard and slide into the paper entry. Move the cardboard sideways to release any stray clippings into the waste tray
Partial holes	Sheets not correctly aligned to punch pattern	Adjust edge guide and test punch scrap sheets until correct
Damaged hole edges	Possibly overloading the machine	Punch plastic covers with paper sheets.Reduce number of sheets being punched



Intimus MP&O BeLux
Generaal de Wittelaan 17B
2800 Mechelen - Belgium+ 32
(0)15 - 29 46 3
info@intimus-mpo.com,
www.intimus-mpo.com